

# appetiser.

*2019 Media Kit*



# what is appetiser?

**appetiser.** is an industry magazine that has been created to further position Bidfood and its suppliers as leaders and innovators of the foodservice industry. This flagship magazine offers readers expert knowledge on all things food, as well as showcasing the latest trends and new products to inspire chefs to re-define their menus. **appetiser.** provides a unique way to engage with customers and, therefore, is an effective indirect sales and brand-building opportunity.





# our audience

**appetiser.** is targeted at all existing and potential customers ordering from the vast array of brands in the foodservice industry. These customers can be based in restaurants, pubs, clubs, hotels, cafes and more. **appetiser.** is distributed directly to Bidfood's national customer base via the network of reps across the 50+ foodservice, meat and fresh branches. In addition, copies are direct mailed to select industry professionals, including well-respected chefs and industry bodies/associations.

**appetiser.** is also available to view online at [appetisermagazine.com.au](http://appetisermagazine.com.au), digitally via EDM (Electronic Direct Mail) and is promoted on our Bidfood social channels.



**3000+** likes  
**3000+** followers



**700+** followers



**1800+** followers



**3300+** followers

**Seasonal** issues

Over **50,000** customers

**EDM campaigns** resulting in a **34.5% open rate** (in comparison to the foodservice industry average of 24.71%) and a **click rate of 15.82%** (in comparison to the industry average of 2.98%) from **30,000+ contacts in our data base**











Average of **20,000 active users** on [bidfood.com.au](http://bidfood.com.au) per week, and a **growing social media following**



# opportunities

## Advertisement spaces throughout the magazine

### Positioning

	Inside Front Cover	Full Page	220mm x 274mm
	Page 2	Half Page (Portrait) - preceding credits/contents page	110mm x 274mm
	Page 4	Full Page - adjacent 'word on the street' (trends section)	220mm x 274mm
	Page 16	Full Page - preceding feature article	220mm x 274mm
	Page 25	Third Page (Landscape) - cooking masterclass feature	220mm x 115mm
	Page 26	Full Page - preceding 'the catch' (all about seafood section)	220mm x 274mm
	Page 32	Full Page - preceding 'eating guide'	220mm x 274mm
	Page 35	Half Page (Portrait) - adjacent 'fyi'	110mm x 274mm
	Inside Back Cover	Full Page	220mm x 274mm
	Back Cover	Full Page	220mm x 274mm

\* Limited spots available, with only 4 editions per year

### Specifications

- Artwork must be supplied as high resolution (300dpi) PDF
- Allow minimum 3mm bleed on all edges. Trim marks are preferred
- For full page adverts allow minimum 15mm exclusion zone inside the trim area. No critical information (eg. logos, text) should be placed within this area. (Example opposite)
- Spot (PMS) colours should not be used (eg. special logo colours). Convert all colours to CMYK (if we convert them for you, the results may not be as you expect)

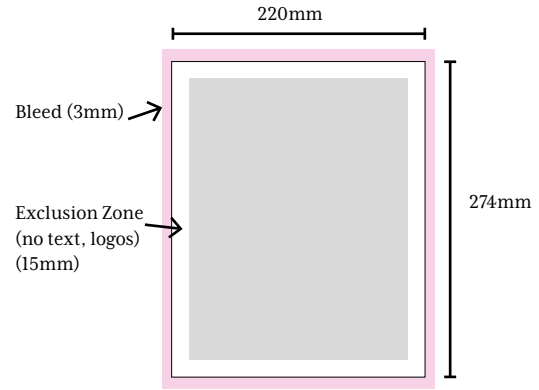





advertising

# opportunities

## Content Requirements

- Advertisements should be in keeping with the style of the publication and offer serving suggestions/inspiration to customers, or brand positioning themes, rather than product line listings
- For the digital version, please provide a URL or Youtube/Vimeo link for video (if applicable)
- Only Bidfood product codes to be used. Wording should be 'Bidfood Code:' rather than 'Product Code:'
- Artwork must not contain suppliers phone numbers or order email address. In addition, references such as 'see suppliers representative' are not permitted. Website addresses can be included
- Cover artwork must have minimal copy. It is our preference that only food/plate/hero shots are used for all cover positions. If the artwork is for brand awareness or positioning, pack shots may be considered
- Inserts can contain the following wording at the bottom of the page: 'To place an order, or for more information, contact your local Bidfood branch'

# contact **US**

For material submissions, please refer to corresponding specifications

For all enquiries and pricing, please contact [marketing@bidfood.com.au](mailto:marketing@bidfood.com.au) or phone (07) 3823 8796